

- NOTES:
- CARD SLOT ACCEPTS $.050 \pm .004$ (1.27 ± 0.10) MODULE THICKNESS. (MEASURED OVER P.C. PADS).
 - ALL PEGS ARE INTERFERENCE FITS TO PCB UNLESS NOTED ON THE DWG.
 - REFER TO PRODUCT SPEC PS-71243-9999 FOR PERFORMANCE SPECIFICATIONS.
 - PRODUCT IS PACKAGED IN TRAYS.
 - RECOMMENDED MODULE LAYOUT SHALL BE PER JEDEC MO-167.
 - RECOMMENDED PLATING ON MODULE PADS: 30 MICROINCH/(0.76 MICROMETER) MINIMUM HARD GOLD (Au) OVER 79 MICROINCH/(2.0 MICROMETER) MINIMUM NICKEL (Ni).
 - PRODUCT WILL HAVE DATE CODE STAMPED ON SIDE OF HOUSING.

MATERIALS:

- HOUSING - GLASS FILLED LIQUID CRYSTAL POLYMER (LCP), UL 94V-0, COLOR: BLACK.
- TERMINAL - PHOSPHOR BRONZE
- LATCHES - GLASS FILLED HIGH TEMPERATURE NYLON, UL 94V-0. LATCH AT PIN #1 END IS IVORY COLOR. LATCH AT OPPOSITE END IS BLACK COLOR.

PLATING:

- CONTACT AREA: GOLD (Au) FLASH; THICKNESS=2-10 MICROINCH/(0.05-0.25 MICROMETER), OVER PALLADIUM-NICKEL (Pd-Ni); THICKNESS=30 MICROINCH/(0.76 MICROMETER) MINIMUM.
- SOLDER TAILS: TIN (Sn); THICKNESS=150 MICROINCH/(3.81 MICROMETER) MINIMUM.
- UNDERPLATE: NICKEL (Ni) OVER ENTIRE CONTACT.

NOTE FOR LEAD FREE CONVERSION:
THE PRIMARY SHIPPING CARTON WILL BE LABELED "COMPLIANT TO ROHS DIRECTIVE 2002/95/EC AND ELV ANNEX II OF DIRECTIVE 2000/53/EC". CARTONS WITHOUT THIS LABEL MAY CONTAIN PRODUCT WITH LEAD.

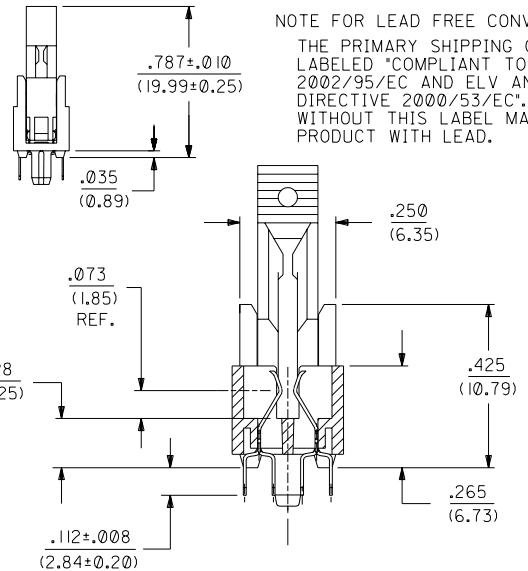
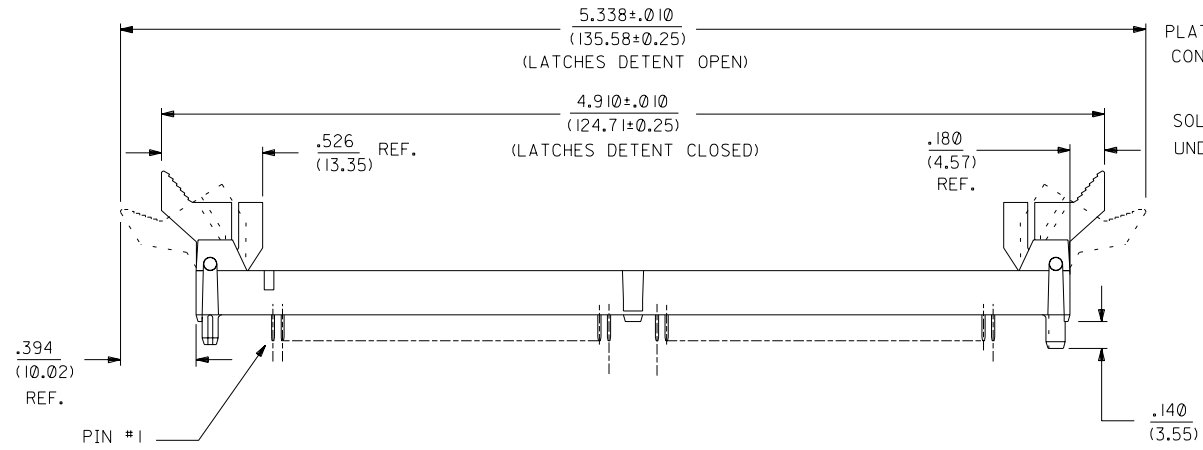
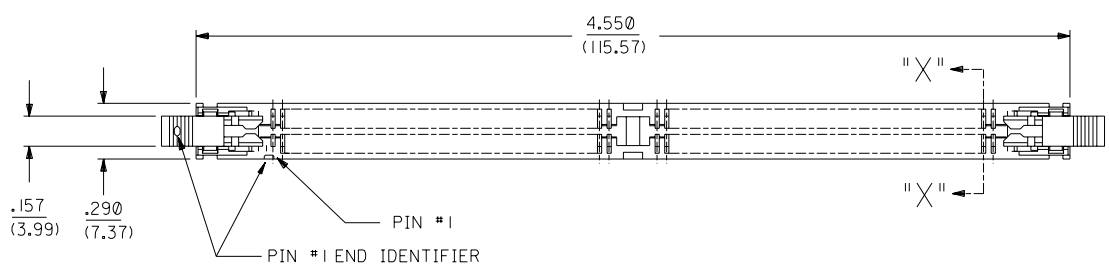

SECTION "X-X"
SCALE 4:1

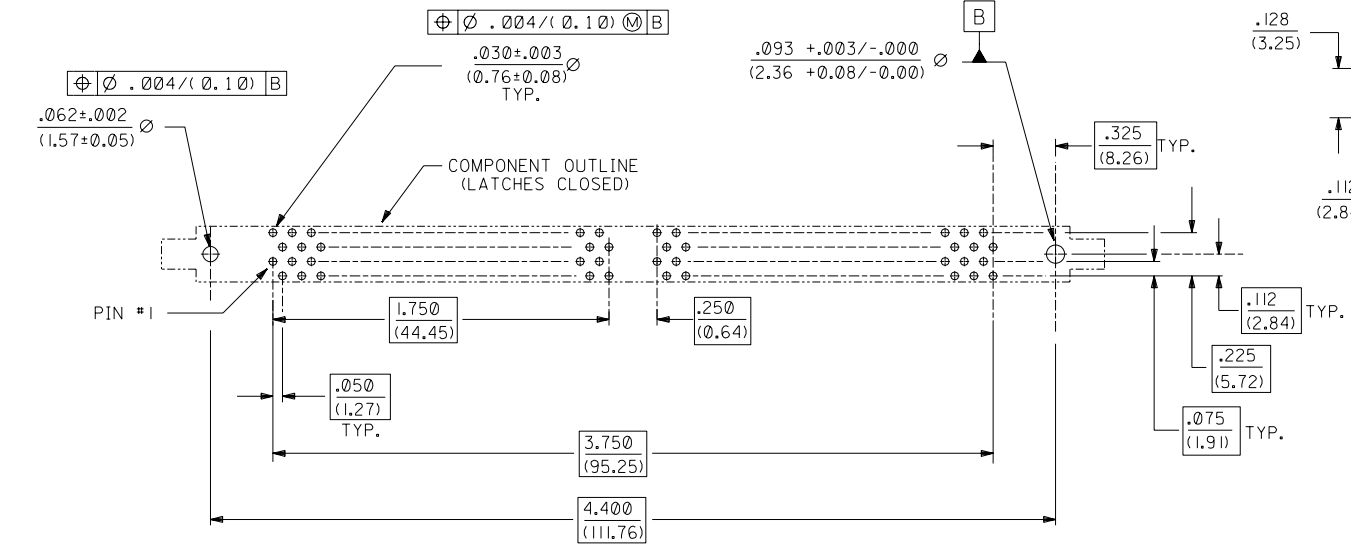

RECOMMENDED
P.C. BOARD HOLE PATTERN
(CONNECTOR SIDE)

FI	ADD LEAD FREE NOTE ECR# UCP2004-1132 DMORGAN 04/03/08
F	CHG. Sn-Pb THICKNESS ECR# UDT1999-0454 DMORGAN 99/08/09
E	REVISED PER ECR# U60883 96-10-1 LAURX
D	REVISED PER ECR# U60883 3-15-96 JCL
C	RELEASED PER ECR# U60836 1-19-96 JCL

DIMENSIONS SHOWN (METRIC) INCH		UNLESS OTHERWISE SPECIFIED TOLERANCES: ANGULAR $\pm 1/2^\circ$		REVISIONS	
3 PLAGE	$\pm .005$	---	---	2	E
2 PLAGE	$\pm .01$	± 0.13		1	FI
1 PLAGE	---	± 0.25			
DRAFT WHERE APPLICABLE MUST REMAIN WITHIN DIMENSIONS				MFG, SH, REV, LTR, REVISIONS	
DRWG. BY: JCL		CHK'D. BY: DCB		PART NO. 71243-0009	
APP'D. BY:		SCALE: 2:1		DRWG. NO. SDA-71243-0009	
FILE NAME: S712439A.DGN		SHEET NO. 1 OF 2		DATE: 1/19/96	
THIS DRAWING CONTAINS INFORMATION THAT IS PROPRIETARY TO MOLEX INC. AND SHOULD NOT BE USED WITHOUT WRITTEN PERMISSION.				DIV. SIZE: CP C	

